

HOLLOW SHAFT ENCODER **ERA-58-B** Series

Product selection guide

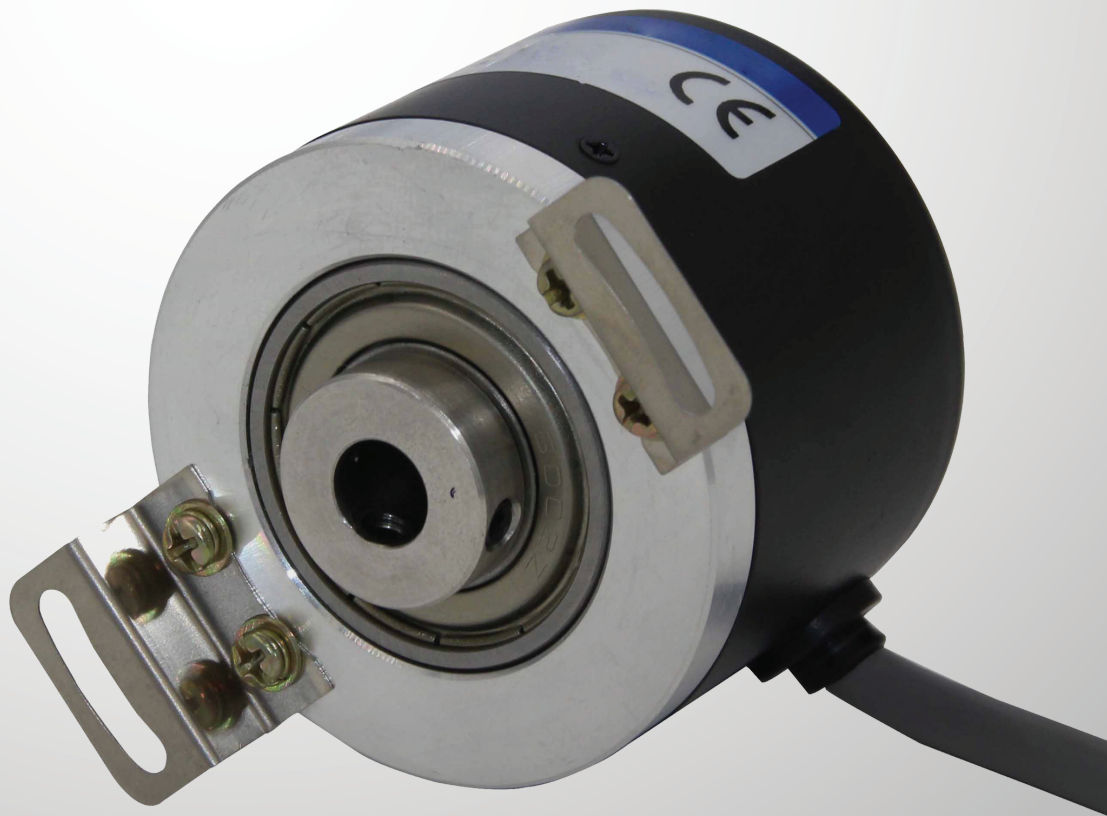

# Applications & Features



ERA-58B His widely applied to kinds of machinery and photoelectric light industry control industry. Multiple output signals are available, resolution up to 6000ppr, others on request. Optoelectronic devices with high reliability, long life, strong anti-interference ability, wide range of operating temperature.

## Part Number

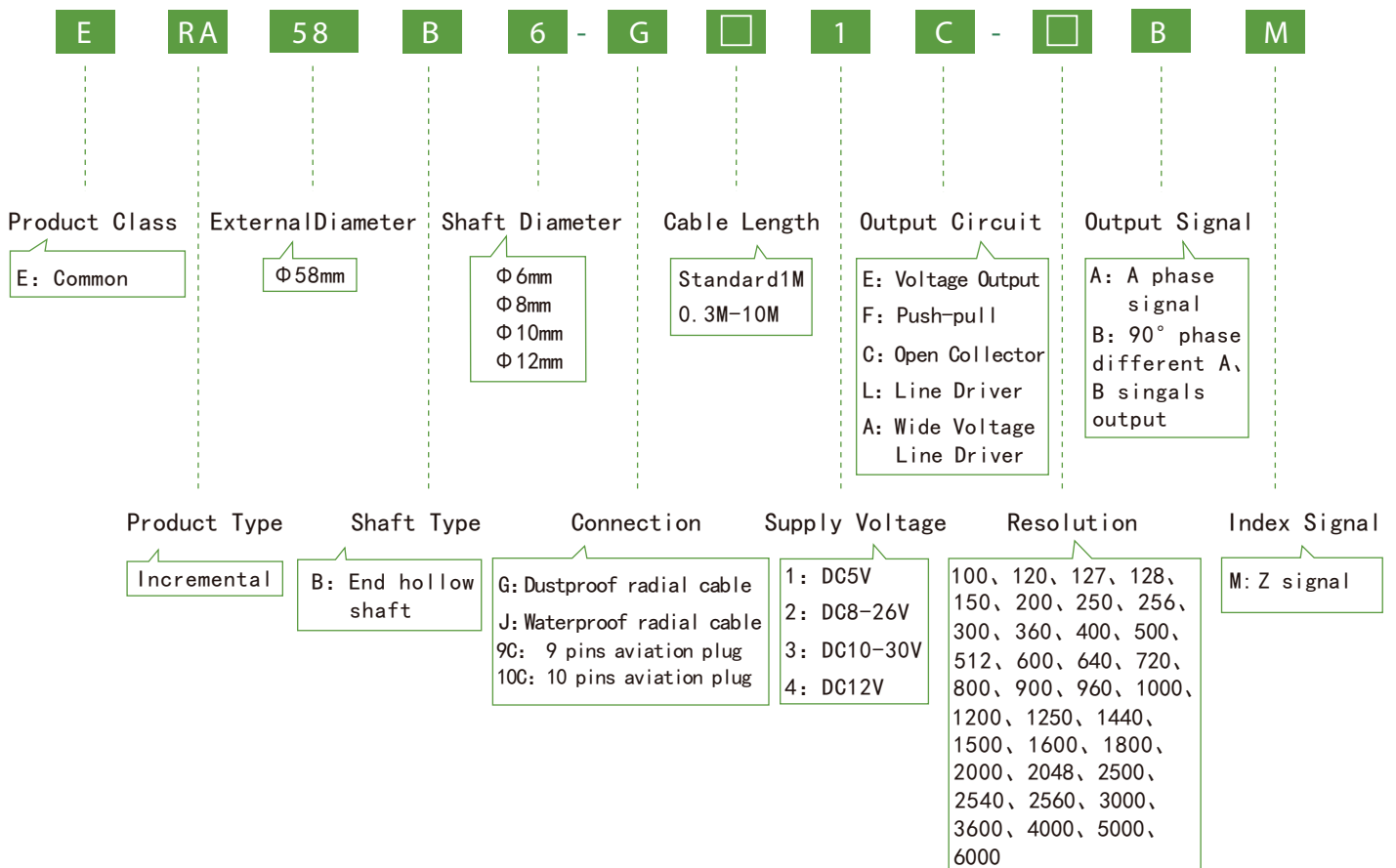

## Electrical Specifications

Output Circuit	Supply Voltate DC (V)	Current Requirement (mA)	(Output Voltage V)		Rise Time (ns)	Fall Time (ns)	Frequency Response (kHz)
			V <sub>H</sub>	V <sub>L</sub>			
E (Voltage)	5±0.25	≤80	>3.5	≤0.7	≤500	≤100	0-300
	8-26	≤120	>VCC-2.5	≤0.7	≤500	≤100	0-300
	10-30						
	12						
F (Push-pull)	5±0.25	≤80	>3.5	≤0.7	≤500	≤100	0-300
	8-26	≤120	>VCC-2.5	≤0.7	≤500	≤100	0-300
	10-30						
	12						

C (Open Collector)	5±0.25	≤60	>VCC-2.5	≤0.7	≤500	≤100	0-300
	8-26						
	10-30						
	12						
L (Line Driver)	5±0.25	≤100	>3.5	≤0.7	≤200	≤200	0-300
A (Wide Voltage Line Driver)	8-26	≤60	>VCC-2.5	≤0.7	≤500	≤100	0-300
	10-30						
	12						

## Output Circuit

E (Voltage)		F (Push-pull)		C (Open Collector)	L, A (Line Driver)
5V	8-26V	5V	8-26V		
					L : 26C31 A : ET7272B

## Output Waveform

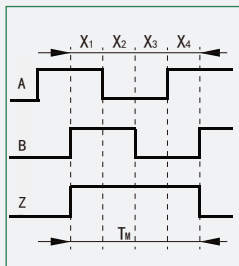

Waveform for C, E, F output

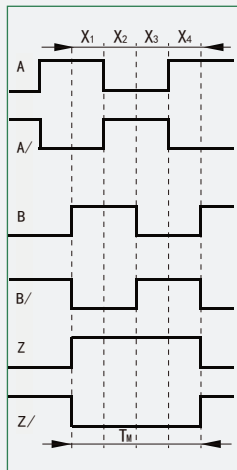

Waveform for L, A output

- Wave Ratio :  $X1+X2=0.5T \pm 0.1T$   
 $X2+X3=0.5T \pm 0.1T$
- Phase Different :  $Xn \geq 0.125T$  ( $n=1, 2, 3, 4$ )
- Absolute Angle Error:  $\leq 0.2T$
- Cycle Error :  $\leq 0.05T$
- $T=360^\circ / N$  ( $N$ =lines count per revolution)
- Width of Z signal
- 1、 $T_m=1T \pm 0.5T$   
 $T_m=nT \pm 0.1T$  ( $n \geq 2$ )
- The phase relationship of Z signal and A, B signal is not stipulated.
- 2、 $T_m=0.5T \pm 0.25T$   
 $T_m=0.25T \pm 0.125T$   
 $T_m=0.25T \pm 0.125T$

The picture shows the clockwise (CW) waveform from the shaft side.

## Mechanical Specifications

Max Speed (r/min)	Starting Torque (N. M)	Max Load (N)		Rotary Inertia (kgm <sup>2</sup> )	Weight (kg)
		Radial	Axial		
6000	$6 \times 10^{-3}$	30	20	$8.5 \times 10^{-6}$	≈0.28

## Dimension

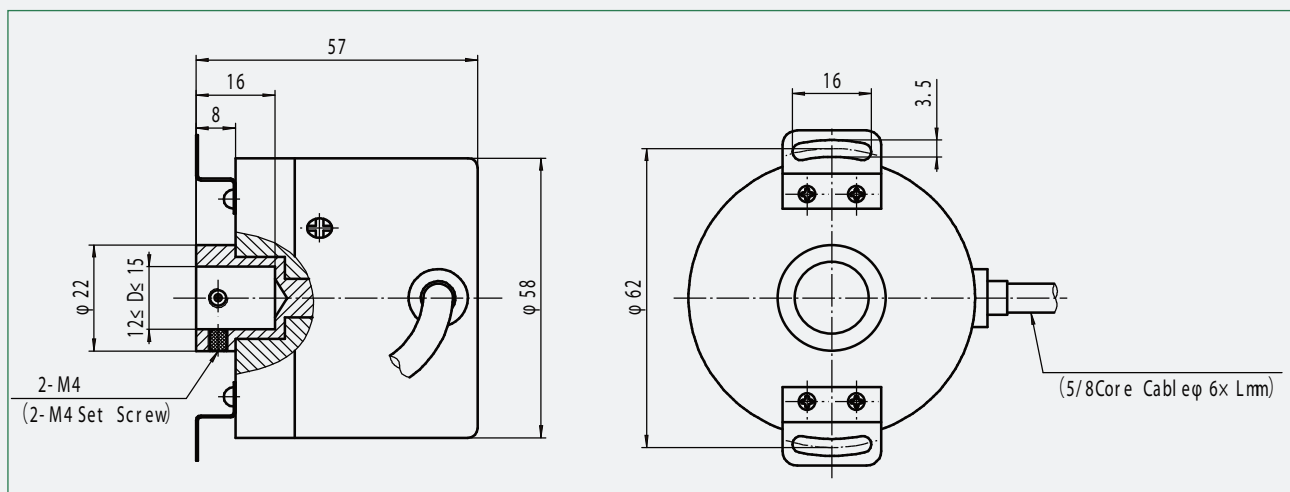

## Environmental Specifications

Operating Temperature (°C)	-20~+85
Storage Temperature (°C)	-30~+95
Relative Humidity	35~85%RH no condensation
Impact Resistance (m/s <sup>2</sup> )	50 (Three times each on x, y, z directions, each time lasts 6ms)
Vibration Resistance (m/s <sup>2</sup> )	20 (10~200Hz, 2h on x, y, z directions)
Protection Class	Common IP54

## Connections

Cable Color	Red	Black	Green	Brown	White	Gray	Yellow	Orange	Shield
E (Voltage)	Vcc	0V	A	/	B	/	Z	/	G
F (Push Pull)	Vcc	0V	A	/	B	/	Z	/	G
G (Open Collector)	Vcc	0V	A	/	B	/	Z	/	G
L, A (Line Driver)	Vcc	0V	A	A/	B	B/	Z	Z/	G

### 9 Pins Aviation Plug

Pins No.	1	2	3	4	5	6	7	8	9
Cable Color	Red	Yellow	White	Black	Green	Gray	Brown	Orange	Shield
E (Voltage)	Vcc	Z	B	0V	A				G
F (Push Pull)	Vcc	Z	B	0V	A				G
C (Open Collector)	Vcc	Z	B	0V	A				G
L, A (Line Driver)	Vcc	Z	B	0V	A	B/	A/	Z/	G

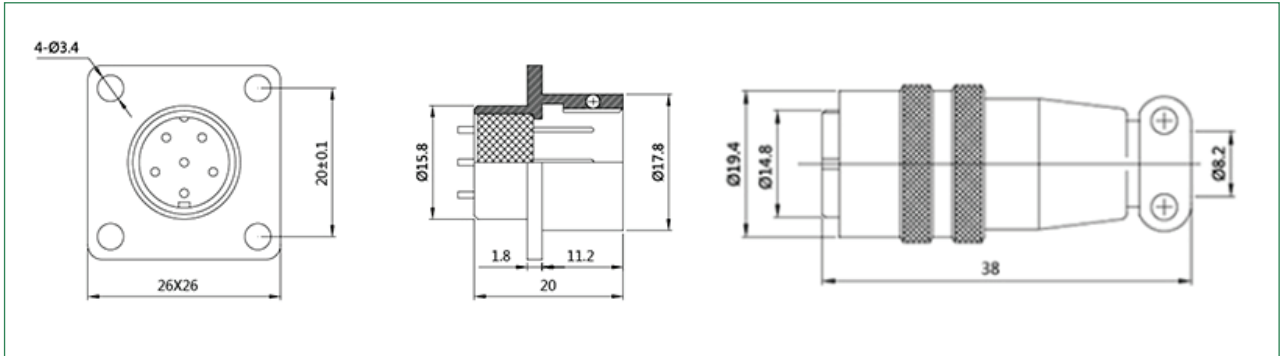

### 10 Pins Aviation Plug

Pins No.	1	2	3	4	5	6	7	8	9	10
Cable Color	Red	Yellow	White	Black	Green	Gray	Brown	Orange	Black	Shield
E (Voltage)	Vcc	Z	B	0V	A				0V	G
F (Push Pull)	Vcc	Z	B	0V	A				0V	G
C (Open Collector)	Vcc	Z	B	0V	A				0V	G
L, A (Line Driver)	Vcc	Z	B	0V	A	B/	A/	Z/	0V	G

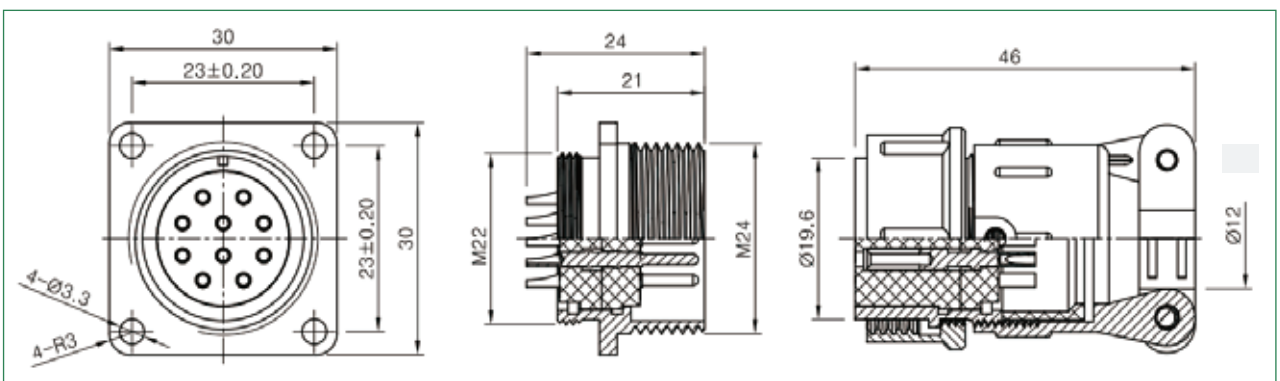

[www.excellaelectronics.com](http://www.excellaelectronics.com)

